



(888) 800-ARIES
824 E. Anaheim St., Ste A
Wilmington, CA 90744

Part No. 203014, 203014-2

Application: 1999 F-250(HD) / F350 REGULAR, SUPER AND CREW CAB

PARTS LIST

<u>ITEM</u>	<u>DESCRIPTION</u>	<u>QUANTITY</u>
1.	FRONT MOUNT BRACKET – DRIVER SIDE	1
2.	FRONT MOUNT BRACKET – PASSENGER SIDE	1
3.	REAR MOUNT BRACKET – DRIVER SIDE	1
4.	REAR MOUNT BRACKET – PASSENGER	1
5.	STEP BAR – DRIVER SIDE	1
6.	STEP BAR – PASSENGER SIDE	1
7.	½-13 X 2.00” LG. HEX HEAD BOLT GRADE 5, ZINC PLATED	4
8.	5/16-18 X 1.25” LG. HEX HEAD BOLT GRADE 5, ZINC PLATED	12
9.	½” SAE FLAT WASHER	4
10.	5/16” SAE FLAT WASHER	20
11.	½” SPLIT LOCK WASHER	4
12.	5/16” SPLIT LOCK WASHER	12
13.	5/16” -18 HEX NUT, FINISHED	8
14.	5/16” -18 NUT CLIP	4

TOOLS REQUIRED

<u>ITEM</u>	<u>DESCRIPTION</u>	<u>QUANTITY</u>
1.	½” SOCKET	1
2.	¾” SOCKET	1
3.	TORQUE WRENCH	1
4.	RATCHET	1

INSTALLATION INSTRUCTIONS

STEP 1

Remove the contents from the box and check for any damage. Verify all parts against the parts list.

STEP 2

Read and understand instructions completely before beginning installation.

STEP 3

Insert nut clips in truck body as shown in **Figure 1**.

FINISH PROTECTION- ARIES PRODUCTS HAVE A HIGH FINISH THAT MUST BE MAINTAINED SUCH AS ANY OTHER HIGH FINISH PRODUCT ON THE VEHICLE. PROTECT THE FINISH WITH A NON-ABRASIVE AUTOMOTIVE WAX. THE USE OF SOAP, POLISH, OR WAX THAT CONTAINS ABRASIVES IS DETRIMENTAL, AS THE COMPOUNDS SCRATCH THE FINISH AND OPEN IT TO CORROSION.

DISCLAIMER- BUYER ASSUMES ALL RISK AND LIABILITY WHATSOEVER FROM THE INSTALLATION AND USE OF ARIES PRODUCTS. ARIES PRODUCTS ARE SOLD AS DECORATIVE ACCESSORIES AND SHOULD NOT BE RELIED UPON AS PROTECTION FOR THE VEHICLE OR OCCUPANTS IN THE EVENT OF A COLLISION OR ROLL OVER. ARIES AUTOMOTIVE ASSUMES NO LIABILITY FOR INJURY, LOSS, INCIDENTAL OR CONSEQUENTIAL DAMAGES IN THE EVENT OF A COLLISION OR ROLLOVER.

DRIVER SIDE
FIGURE 1

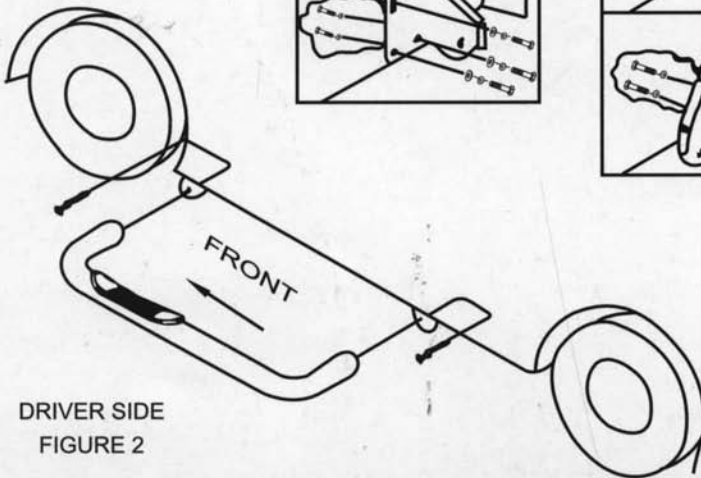
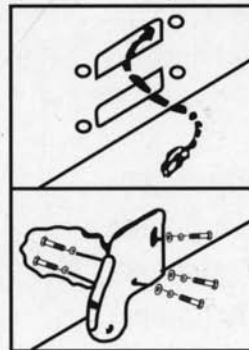
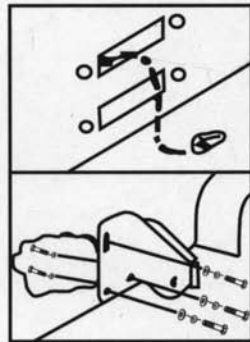
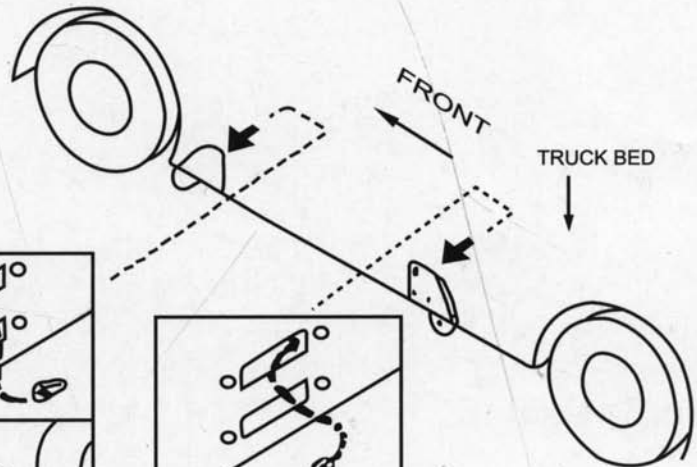

ASSEMBLY AND INSTALLATION VIEW OF DRIVER SIDE - PASSENGER SIDE OPOSITE