



INSTALLATION INSTRUCTIONS

GRILLE GUARD

01-04 FORD RANGER XLT / EDGE 2/4WD

Part # 3053 and 3053-2

PARTS LIST:

1	Grille Guard	8	7/16" x 1 1/4" Hex Head Bolts
1	Driver/Left Mounting Bracket	8	7/16" Hex Nuts
1	Passenger/Right Mounting Bracket	16	7/16" Flat Washers
1	Driver/Left Top Bracket	2	1/2" x 4" Hex Head Bolts
1	Passenger/Right Top Bracket	2	1/2" Nylock Nuts
1	Driver/Left Mounting Bracket Support	4	1/2" Flat Washers
1	Passenger/Right Mounting Bracket Support	2	1/4" x 3/4" Hex Head Bolts
1	Driver/Left Top Support Bracket	2	1/4" Flat Washers
1	Passenger/Right Top Support Bracket	2	1/4" Nylock Nuts
2	12-1.75mm Nylock Nut	2	3/8" x 3/4" Hex Head Bolts
2	12mm ID x 29mm Flat Washers	2	3/8" Nylock Nuts
		4	3/8" Flat Washers

PROCEDURE:

1. REMOVE CONTENTS FROM BOX. VERIFY ALL PARTS ARE PRESENT. READ INSTRUCTIONS CAREFULLY BEFORE STARTING INSTALLATION. DO NOT ATTEMPT INSTALLATION ALONE; PERSONAL INJURY OR DAMAGE TO THE TRUCK MAY RESULT.
2. On the driver side, locate and loosen the factory nut located directly behind the bumper by the front end of the frame (**Figure 2**).
3. Position driver side Mounting Bracket over factory bolt. The hole on the side of the Mounting Bracket should line up with the factory hole on the frame. Position the driver side Mounting Support Bracket on the other side of frame as shown in **Figure 2**. Secure Mounting Bracket and Mounting Support Bracket to frame with the included (1) 1/2" x 4" Hex head Bolt, (2) 1/2" Flat Washers, and (1) 1/2" Nylock Nut (**Figure 3**). **NOTE:** Do not fully tighten any bolts until you have the complete Grille Guard assembled, as you may have to adjust Brackets and Grille Guard.
4. Position Top Support Bracket through factory bolt where you previously inserted the Mounting Bracket. Secure Mounting Bracket and Top Support Bracket together to vehicle using the included (1) 12mm Nylock Nut and (1) 12mm Flat Washer (**Figure 4**).
5. From the front of the vehicle, insert the Top Bracket between bumper and factory grille shell. Align hole on the Top Bracket with hole on the Top Support Bracket already installed. Secure them with the included (1) 3/8" x 3/4" Hex Head Bolt, (1) 3/8" Nylock Nut, (2) 3/8" Flat Washers (**Figure 4**).
6. Repeat steps 2-5 for passenger side.
7. With help position Grille Guard on the outer side of Mounting Brackets. Attach Grille Guard to Mounting Brackets with the included (6) 7/16" x 1 1/4" Hex Head Bolts, (6) 7/16 Nylock nuts, and (12) 7/16" Flat Washers.
8. Attach Grille Guard to Top Brackets using the Included (2) 1/4" x 3/4" Hex Head Bolts, (2) 1/4" Nylock Nuts, and (2) 1/4" Flat Washers.
9. Level and adjust Grille Guard; and then tighten all hardware at this time.
10. Do periodic inspections to the installation to make sure that all hardware is secure and tight.

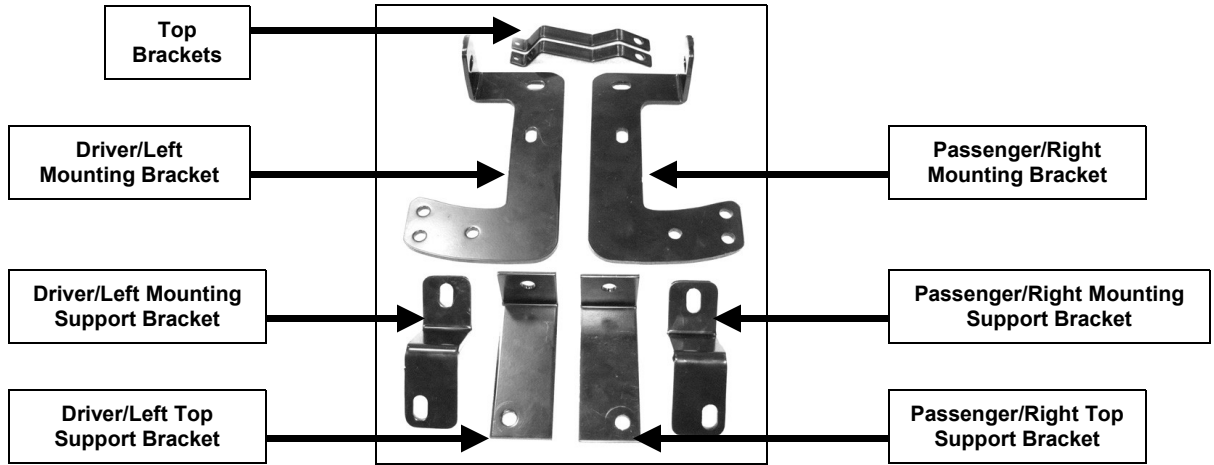

Figure 1

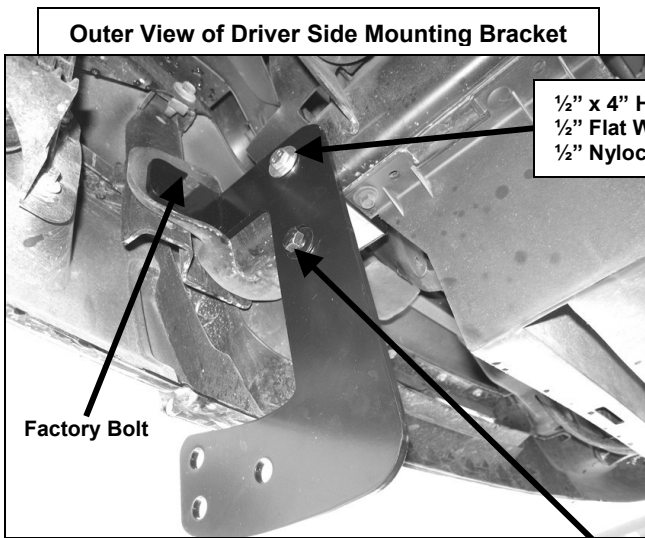

Figure 2

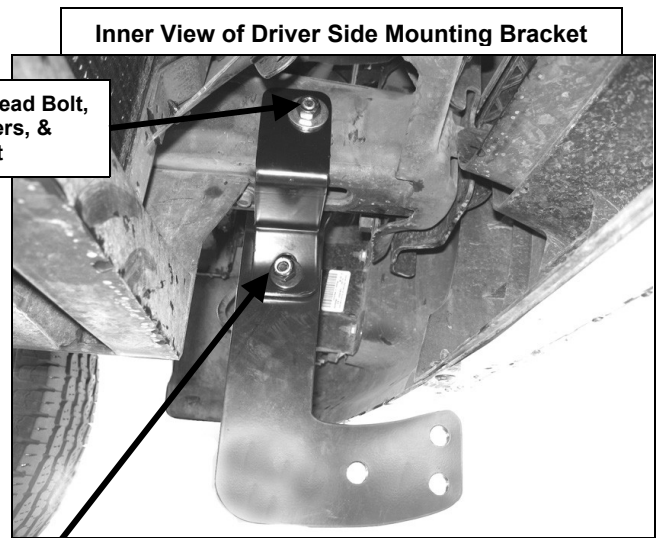

Figure 3

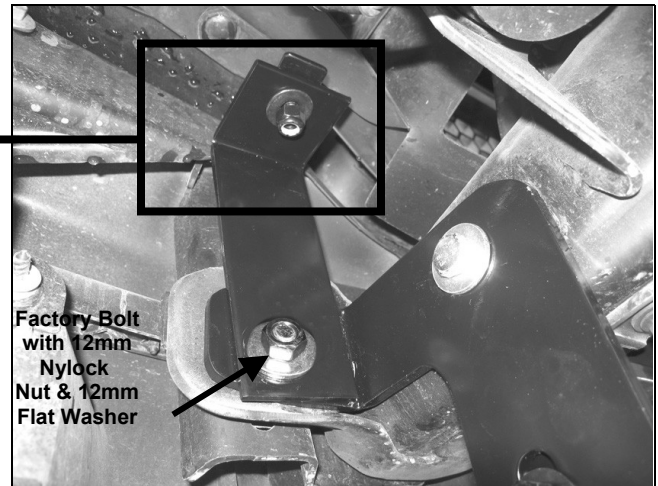
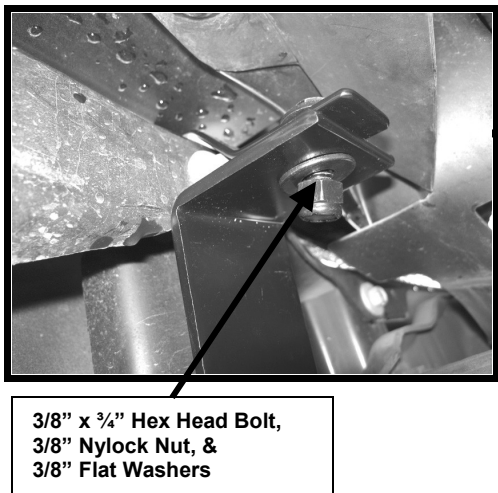

Figure 4