



INSTALLATION INSTRUCTIONS

DELUXE OVAL PART #D224013/11-2
2000 - 2007 GMC HEAVY DUTY CREW CAB 2/4WD
2000 - 2007 CHEVROLET HEAVY DUTY CREW CAB 2/4WD
01-06 SUBURBAN 1500/YUKON XL/01-06 AVALANCHE

PARTS LIST

- | | |
|---------------------------------------|------------------------------|
| (2) OVAL TUBES WITH STEPS | (4) ½" x 2" HEX HEAD BOLTS |
| (2) FRONT MOUNT BRACKETS | (10) ½" FLAT WASHERS |
| (2) REAR MOUNT BRACKETS | (10) ½" SPLIT LOCK WASHERS |
| (2) CENTER MOUNT BRACES | (2) 3/8" x 1" HEX HEAD BOLTS |
| (6) M12 – 1.75 x 120mm HEX HEAD BOLTS | (2) 3/8" FLAT WASHERS |
- (note- these bolts only used for 2005 and before- Use existing bolts for 06-up)**
- (4) 1.44" OD SPACER WASHER
- (2) FRONT SPACER TUBES (SHOWN IN FIG 1.2) 

PROCEDURE

1. Begin installation by working on driver side of the vehicle (see Figures 1.1 – 1.4).
2. From underneath truck, loosen and remove body mount bolts that run upward through mounts into floorboard. Attach and secure Front Mount Bracket to underside of vehicles front body mount, sandwiching the spacer tube shown (see Figure 1.2) with (1) M12 – 1.75 x 120mm bolt, (1) ½" split lock washer, and (1) ½" flat washer. Hand Tighten.
3. Attach and secure Rear Mount Bracket to underside of vehicles rear body mount as shown in Figure 1.4, in same manner as the front. Repeat for Center Brace, but insert (2) 1.44" OD spacer washers between Center Brace and center body mount (see Figure 1.3).
4. Attach Side Tube to Front and Rear Brackets using (1) ½" x 2" bolt, (1) ½" lock washer and (1) ½" flat washer for each bracket, and hand tighten. Fasten Center Brace to Side Tube using (1) 3/8" x 1" bolt, and (1) 3/8" flat washer. Adjust Side Tube so that it is level and centered, and tighten all bolts to complete the driver-side assembly.
5. Repeat process for passenger side of vehicle to complete installation.

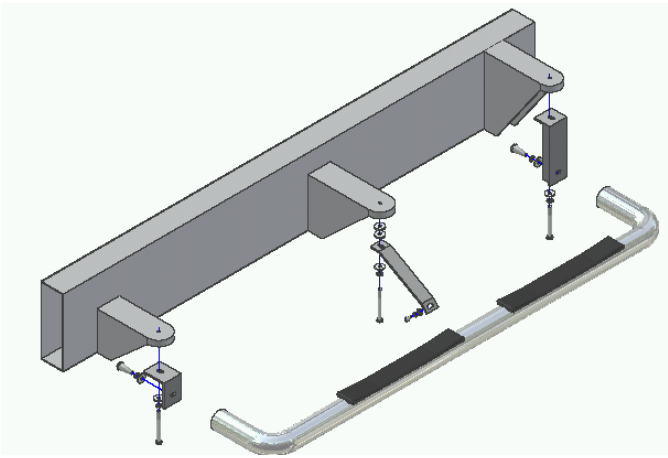

Figure 1.1 – Driver-Side Full Assembly View

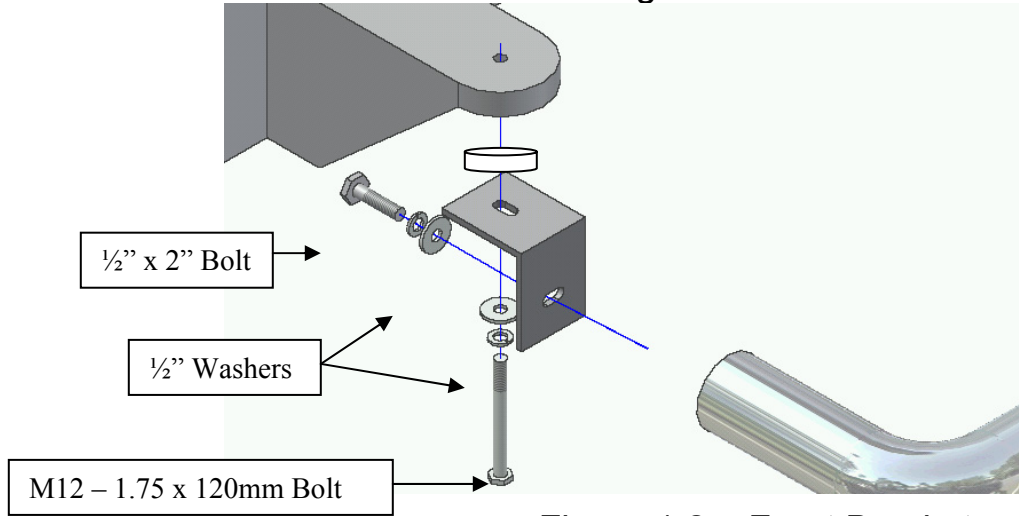

Figure 1.2 – Front Bracket

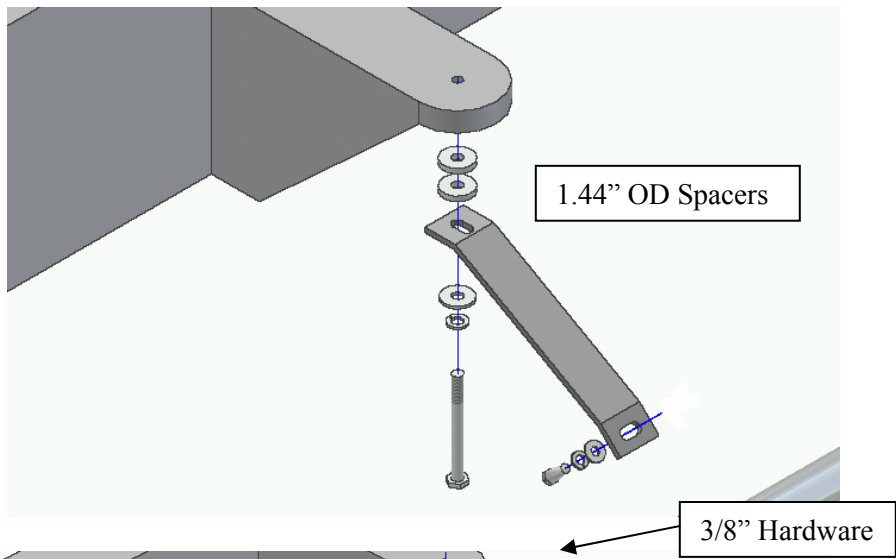

Figure 1.3 –

Center Brace

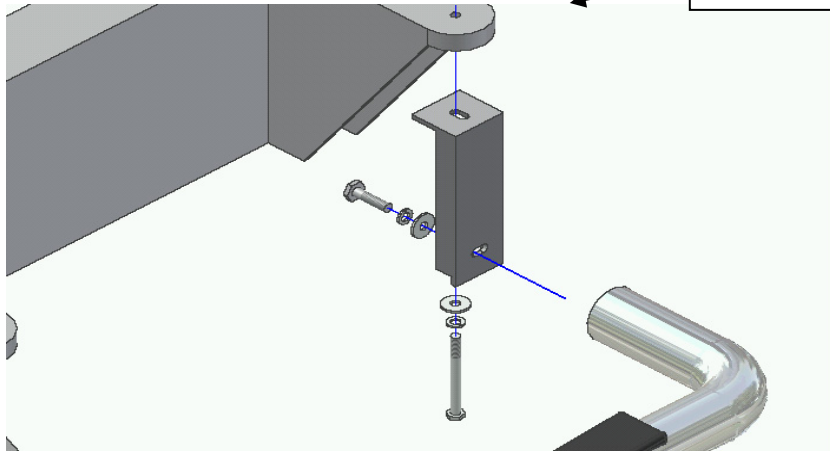



Figure 1.4 – Rear Bracket

FINISH PROTECTION- ARIES PRODUCTS HAVE A HIGH FINISH THAT MUST BE MAINTAINED SUCH AS ANY OTHER HIGH FINISH PRODUCT ON THE VEHICLE. PROTECT THE FINISH WITH A NON-ABRASIVE AUTOMOTIVE WAX. THE USE OF SOAP, POLISH, OR WAX THAT CONTAINS ABRASIVES IS DETRIMENTAL, AS THE COMPOUNDS SCRATCH THE FINISH AND OPEN IT TO CORROSION.

DISCLAIMER- BUYER ASSUMES ALL RISK AND LIABILITY WHATSOEVER FROM THE INSTALLATION AND USE OF ARIES PRODUCTS. ARIES PRODUCTS ARE SOLD AS DECORATIVE ACCESSORIES AND SHOULD NOT BE RELIED UPON AS PROTECTION FOR THE VEHICLE OR OCCUPANTS IN THE EVENT OF A COLLISION OR ROLL OVER. ARIES AUTOMOTIVE ASSUMES NO LIABILITY FOR INJURY, LOSS, INCIDENTAL OR CONSEQUENTIAL DAMAGES IN THE EVENT OF A COLLISION OR ROLLOVER