

STEP 5: Level and adjust Bull Bar as desired and tighten all fasteners.
 Recommended torque values are 64 Ft. Lbs. for 1/2" fasteners, 10 Ft. Lbs. for 6mm fasteners, and 15 Ft. Lbs. for 5/16" fasteners.

LIGHT INSTALLATION: Insert threaded stud on base of the light through hole in cross tube. Using a ratchet, extension and socket for correct size of nut supplied, insert through large clearance hole in bottom of cross tube. Thread nut and washers on stud and tighten. SEE FIGURE 1. NOTE: A short socket, not a deep well works best to get the nut started. Fits most 5" round or rectangle lights. Some lights may require replacing included mount/isolator with rubber bumpers provided. Mounting stud of 1/2" or less required. Plug mount holes with caps provided if not installing lights.

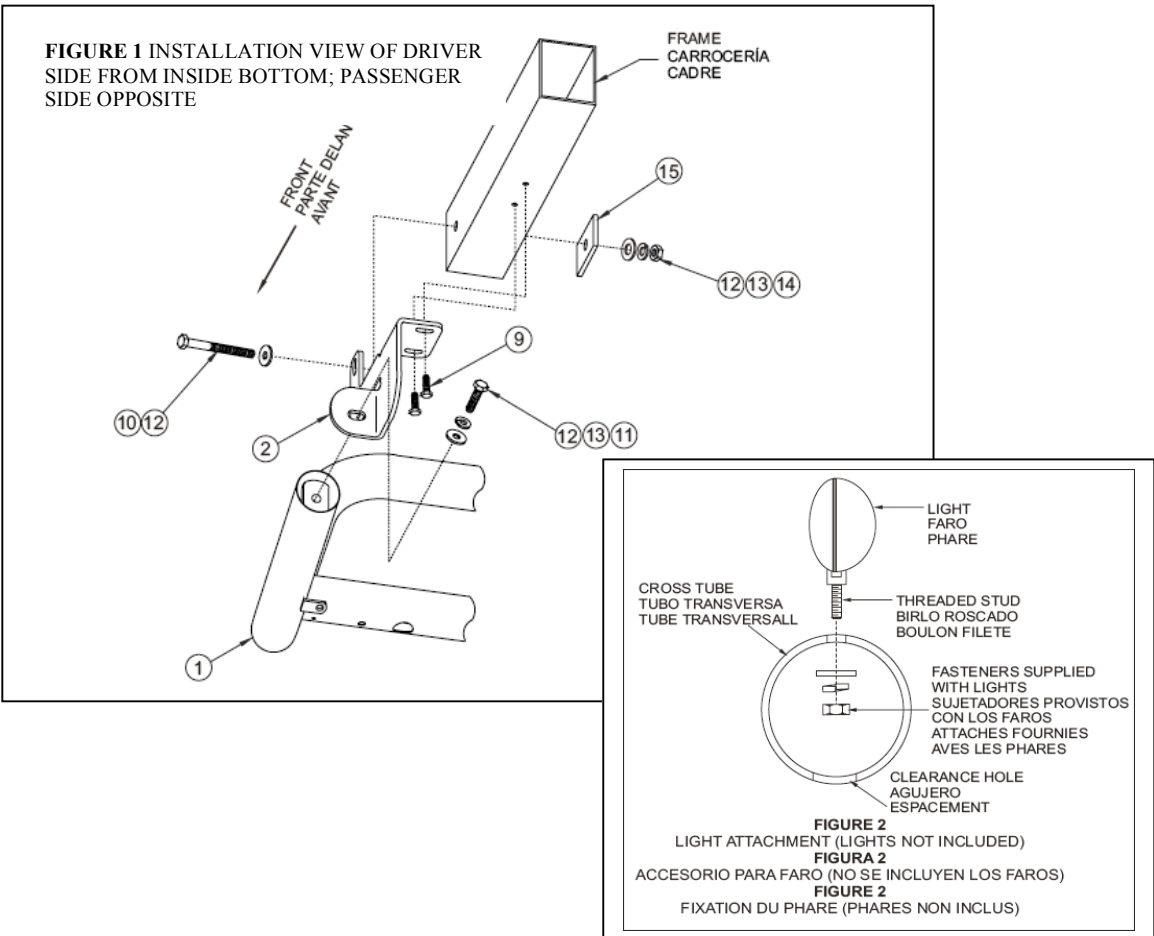

FINISH PROTECTION- *ARIES PRODUCTS HAVE A HIGH FINISH THAT MUST BE MAINTAINED SUCH AS ANY OTHER HIGH FINISH PRODUCT ON THE VEHICLE. PROTECT THE FINISH WITH A NON-ABRASIVE AUTOMOTIVE WAX. THE USE OF SOAP, POLISH, OR WAX THAT CONTAINS ABRASIVES IS DETRIMENTAL, AS THE COMPOUNDS SCRATCH THE FINISH AND OPEN IT TO CORROSION.*

DISCLAIMER- BUYER ASSUMES ALL RISK AND LIABILITY WHATSOEVER FROM THE INSTALLATION AND USE OF ARIES PRODUCTS. ARIES PRODUCTS ARE SOLD AS DECORATIVE ACCESSORIES AND SHOULD NOT BE RELIED UPON AS PROTECTION FOR THE VEHICLE OR OCCUPANTS IN THE EVENT OF A COLLISION OR ROLL OVER. ARIES AUTOMOTIVE ASSUMES NO LIABILITY FOR INJURY, LOSS, INCIDENTAL OR CONSEQUENTIAL DAMAGES IN THE EVENT OF A COLLISION OR ROLLOVER.



Aries Automotive Accessories, Inc.
 P.O. Box 1687
 Lomita, CA 90717

Thank you for choosing Aries products
 For Customer Service Support please call: (888) 800-2743



Applications Guide

for:

BULL BAR ASSEMBLIES	
35-3009	B35-3009

1998-08 FORD Ranger 2/4 Wheel Drive

ITEM	QTY	CONTENTS	TOOLS
1	1	Bull Bar Assembly	3/4" Socket
2,3	2	Bracket, Passenger (2) and Driver (3)	3/4" Wrench
4	2	Mount Plate	1/2" Socket
5	2	Plastic Plug	10mm Socket
6	4	Rubber Bumper	Flat Screwdriver
7	4	5/16-18 x 1.00" Self Tapping Screw	Ratchet
8	2	1/2-13 x 4.00" Hex Head Bolt	Torque Wrench
9	2	1/2-13 x 2.00" Hex Head Bolt	
10	6	1/2" Flat Washer	
11	4	1/2" Lock Washer	
12	2	1/2-13 Hex Nut	

- STEP 1:** Remove the contents from box and check for damage. Verify all parts are present. Read instructions completely before beginning.
- STEP 2:** NOTE: It may be necessary to remove/relocate front license plate and license plate bracket. It is not required, but strongly recommended. If local/state laws require a license plate, license plate relocation kit 32-0055 is available.
- STEP 3:** If vehicle has a plastic shroud mounted to bottom of frame, remove bolts with 10mm socket and remove "push-type" fasteners from shroud. Place brackets against bottom of frame, reinstall plastic shroud with factory bolts and replace "push-type" fasteners with 5/16" self tapping screws. Attach brackets to outside face of frame members with 1/2" fasteners and mount plate as shown.
- STEP 4:** Attach Bull Bar using 1/2" fasteners as shown. SEE FIGURE 1.

