



(888)-800-ARIES

BULL BAR
35-3002 INSTRUCTION SHEET

2004 FORD F-150 2/4 WD

<u>QTY.</u>	<u>ITEM</u>	<u>CONTENT</u>
1	1	BULL BAR
2	2	BRACKETS-PASSENGER & DRIVER SIDE
4	3	RUBBER BUMPER
4	4	BOLT PLATE
4	5	1/2" FLAT WASHER
4	6	1/2" LOCK WASHERS
4	7	1/2-13 HEX NUT
6	8	3/8 -16 X 1.25" HEX HEAD BOLT
12	9	3/8" FLAT WASHERS
6	10	3/8" LOCK WASHERS
6	11	3/8"-16 HEX NUT
2	12	M10-1.50 X 30MM HEX HEAD BOLT
2	13	10MM FLAT WASHER
2	14	10MM LOCK WASHER

STEP 1 REMOVE CONTENTS FROM BOX AND VERIFY ALL PART ARE PRESENT. READ INSTRUCTIONS COMPLETELY BEFORE BEGINNING.

STEP 2 IT MAY BE NECESSARY TO REMOVE/RELOCATE FRONT LICENSE PLATE AND LICENSE PLATE BRACKET. IT IS NOT REQUIRED, BUT STRONGLY RECOMMENDED.

VEHICLES WITH TOW HOOKS

STEP 3 REMOVE TOW HOOKS BY REMOVING FRONT AND REAR BOLTS. NOTE: TOW HOOKS WILL NOT BE RE-INSTALLED . MAKE SURE BOLT PLATE IN FRAME STAYS ALIGNED WITH HOLES.

STEP 4 POSITION BOTTOM BRACKET UP TO BOTTOM OF FRAME AND REPLACE TOW HOOK BOLTS. **SEE FIGURE 2.** GO TO STEP 6.

VEHICLE WITHOUT TOW HOOKS.

STEP 3 INSERT TWO BOLT PLATES THROUGH THE END OF THE FRAME AND INTO BOTTOM FRAME HOLES. NOTE: IT MAY BE NECESSARY TO REMOVE THE LOWER PLASTIC PORTION OF THE BUMPER TO GAIN ACCESS TO ENDS OF THE FRAME RAILS. THE INDENTED POCKETSIN THE LOWER BUMPER WILL NEED TO BE CUT OUT TO ALLOW BOTTOM BRACKETS TO PASS THROUGH. SEE FIGURE 2.

5. ATTACH BULL BAR TO BRACKETS USING 3/8" FASTENERS AS SHOWN. LEVEL AND ADJUST BULL BAR AS DESIRED. TORQUE TOW HOOKS BOLTS TO 75 FT. LBS. AND 1/2" FASTENERS TO 65 FT.LBS; 10MM FASTENERS TO 35 FT.LBS. AND 3/8" FASTENERS TO 30 FT. LBS.

FINISH PROTECTION- ARIES PRODUCTS HAVE A HIGH FINISH THAT MUST BE MAINTAINED SUCH AS ANY OTHER HIGH FINISH PRODUCT ON THE VEHICLE. PROTECT THE FINISH WITH A NON-ABRASIVE AUTOMOTIVE WAX. THE USE OF SOAP, POLISH, OR WAX THAT CONTAINS ABRASIVES IS DETRIMENTAL, AS THE COMPOUNDS SCRATCH THE FINISH AND OPEN IT TO CORROSION.

DISCLAIMER- BUYER ASSUMES ALL RISK AND LIABILITY WHATSOEVER FROM THE INSTALLATION AND USE OF ARIES PRODUCTS. ARIES PRODUCTS ARE SOLD AS DECORATIVE ACCESSORIES AND SHOULD NOT BE RELIED UPON AS PROTECTION FOR THE VEHICLE OR OCCUPANTS IN THE EVENT OF A COLLISION OR ROLL OVER. ARIES AUTOMOTIVE ASSUMES NO LIABILITY FOR INJURY, LOSS, INCIDENTAL OR CONSEQUENTIAL DAMAGES IN THE EVENT OF A COLLISION OR ROLLOVER.

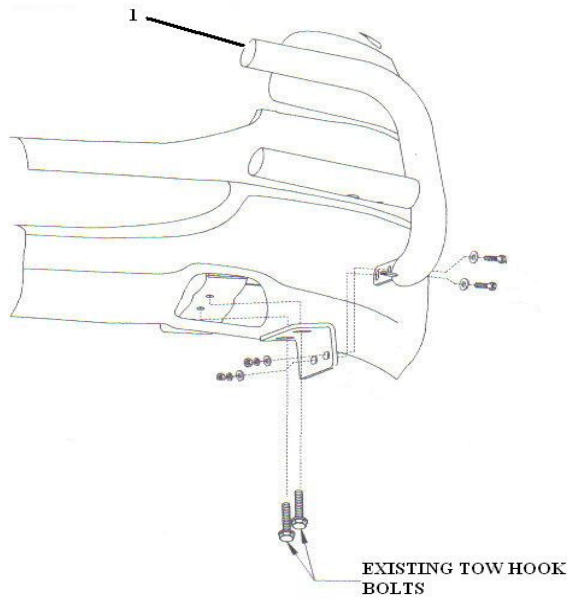

FIGURE 2

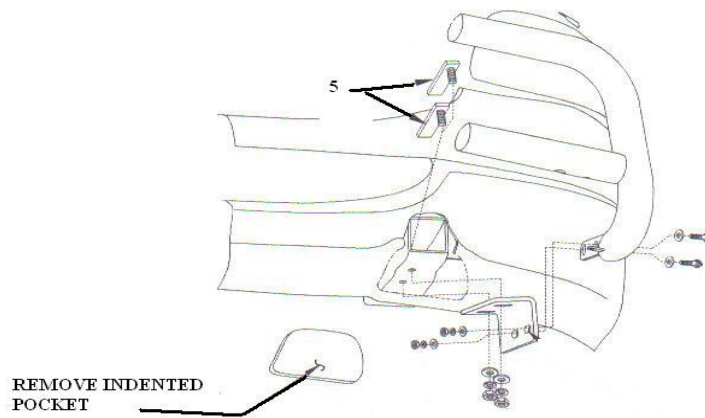

FIGURE 3